GXS

DRY SCREW PUMPS & COMBINATIONS



WWW.EDWARDSVACUUM.COM

VACUUM & ABATEMENT

INNOVATIVE TECHNOLOGY

GLOBAL STRENGTH

LOCAL SUPPORT



FAST

Dry pumping down to 1×10^{-3} mbar ultimate vacuum

ROBUST

Reliable operation in harsh applications

COMPACT

Smaller footprint than pumps of similar capabilities

ECONOMICAL

Affordable capital investment and low cost of ownership

ENVIRONMENTAL

Smooth, quiet running with low power and utilities consumption





GXS Dry Screw Pumps & Combinations

Edwards, the pioneer in dry pumping technology, launches a new generation of dry vacuum pumps.

With more than 90 years vacuum experience and over 150,000 dry pumps installed world wide, Edwards leads the way in every vacuum application including those handling harsh dust and process contaminants.

Edwards GXS range incorporates our unique screw technology with a world leading high efficiency drive to achieve excellent vacuum performance and low running costs. With advanced temperature control, low maintenance and long service intervals, the GXS is the most robust and economical vacuum pump that establishes a new standard in dry pumping.

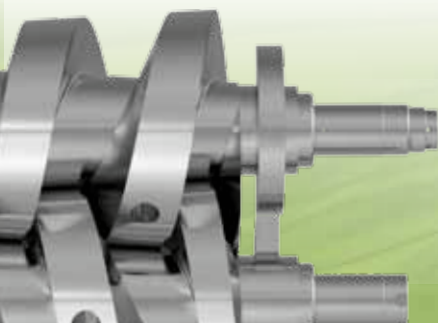

Applications

GXS pump and pump/booster combinations may be configured for optimum performance. The range of applications include:

Coating

- Architectural glass coating
- Optical lens coating
- Reflective coating
- Roll coating
- Thin film coating

Drying

- Freeze drying food/pharmaceutical
- Pipeline drying
- Transformer drying

LED manufacture

Metallurgy

- Brazing/welding
- Casting
- Surface and heat treatments
- Sintering
- VIM and VAR

Plasma processes

- Cleaning
- Sterilisation

Solar

- Lamination
- Silicon crystal growing
- Solar coating

Vacuum chamber evacuation

- Fusion chamber
- Load-lock
- R&D
- Space chamber

Vacuum packaging

- Food
- Pharmaceutical

Systemisation

The range of GXS screw pumps may be further enhanced through the addition of accessories which have been specially designed to give optimum performance in a wide range of applications.

For detailed advice and availability please consult one of our applications engineers.

Inlet and Exhaust accessories (ISO-ANSI and NW-ANSI)

- Foreline spool adaptor
- Inlet isolation valve (with position indicator)
- Inlet spool
- Inlet filter
- Inlet cyclone
- Inlet knock-out pot
- Exhaust knock-out pot
- Cleanable and drainable silencer
- Exhaust check valve

Control and monitoring accessories

- Operator panel with IP54 enclosure
- MCM microTIM (I/O control module)
- Profibus DP control module
- Cooling water flow sensor
- Purge gas flow switch
- Instrument pack (PT100, ASG and cables)

Special accessories

- IP54 enclosure
- Solvent injection
- Heated/insulated exhaust
- Air blast cooler





Features & Benefits

Designed for high reliability

Edwards patented screw-rotor design delivers excellent pumping speed and is part of an advanced thermal management system that maximises pump performance and life of the seals, bearings and motor, to ensure long pump service life.

Adaptable to a wide range of applications

GXS pumps are offered with a range of purge options, filters, catchpots, inlet isolation valves and silencers; together with our special high flow purge and solvent flush accessory enabling the inside of the pump to be kept clean without disassembly.

Long service intervals

Long-life non-oxidizing gearbox oil enables service intervals of up to 5 years to be achieved.

Low cost of ownership

Custom high-efficiency motor and drive system with advanced seal technology provides for greatly reduced power consumption. Minimal cooling water and purge gas requirements coupled with improved powertrain technology provide for long service intervals and near maintenance-free operation.

Minimum workplace and environmental impact

GXS pumps are incredibly compact compared to pumps of similar capabilities. Edwards advanced screw-rotor design provides for remarkably quiet, low vibration operation even without a silencer.

Simple to install and operate

GXS pumps are easily wheeled or fork-lifted into position, coupled to the process and services using the supplied mating connectors and run at the push of a button.

Ideal for integration into larger systems

GXS pumps and combinations are supplied with serial and LAN-based communications plus web-serving capability as standard. Optional modules are available to add parallel (digital I/O) and Profibus control functionality.

Onboard PID pressure control

Allows the pump to control the chamber pressure without the need for additional control hardware. Cable option required.

At your service

Edwards has highly skilled applications engineers who will advise on the optimum configuration for your process or application.

GXS Innovative Screw Technology

3 Advanced pumping mechanism design

- Enhanced screw-type rotor design results in smooth, gradual compression along the length of the rotor for improved thermal control and optimised pumping at all inlet pressures
- Integrated heat management and unique rotor and stator design features provide argon gas pumping capability at full concentration
- Advanced machining techniques and design features eliminate the need for rotor coatings while maintaining superb ultimate vacuum performance
- Improved manufacturing technology and design contributes to low vibration and extremely quiet running without a silencer

2 Bearing and lubrication

- Oil lubricated gears eliminate grease and the need for periodic maintenance
- Uses advanced quality bearings and special purpose oil with low vapour pressure for application compatibility and greatly improved life

1 Double ended shaft support

- Non-cantilever design provides secure rotor support for extremely low vibration and superior starting reliability, especially on harsh processes
- Superior liquid and powder handling. Tests demonstrate a five litre water slug and one kilogram fine powder slug handling capability

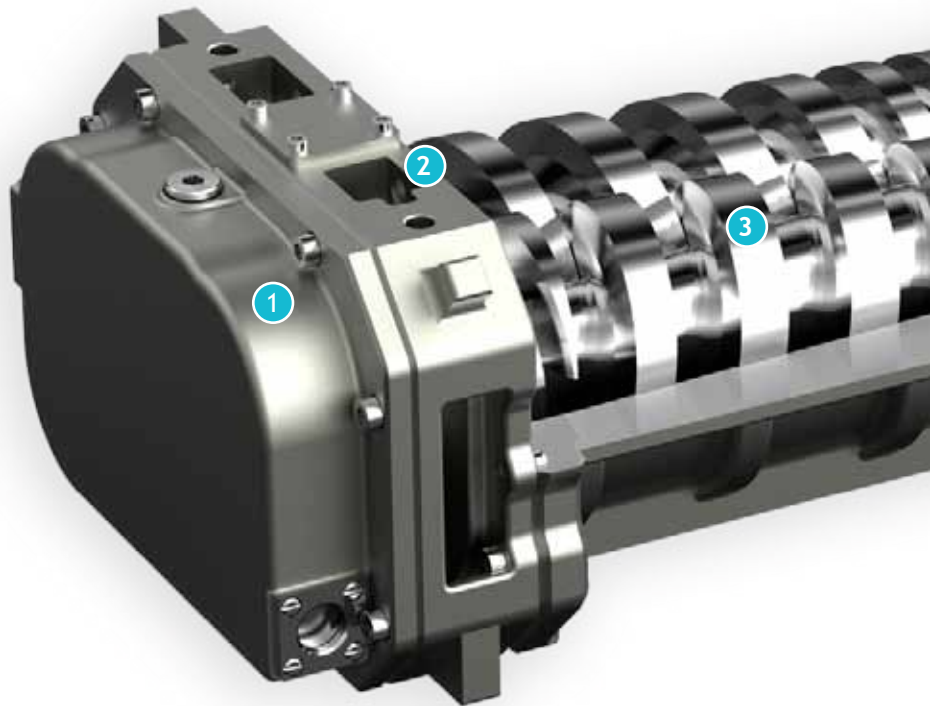

Built-in control panel

- All pumps are fitted with a built-in control panel for direct local control of the pump
- Full start / stop control with indication of running mode and state of the pump with a connector for an optional Pump Display Terminal (PDT) for improved diagnostic and configuration capability



4 Advanced shaft sealing technology

- Non-contacting long-life seals with integral oil blocking labyrinth seal provides for highly effective sealing
- Combined with a six litre per minute seal purge the gearbox is protected from contamination and the vacuum space is kept free of oil

5 World leading motor and drive technology

- Extremely high efficiency motors with electronic drives deliver maximum torque performance for difficult processes
- Hermetically sealed motor eliminates oil leaks and improves pump reliability
- Water-cooled motors and drives provide for improved reliability and long life to reduce service costs

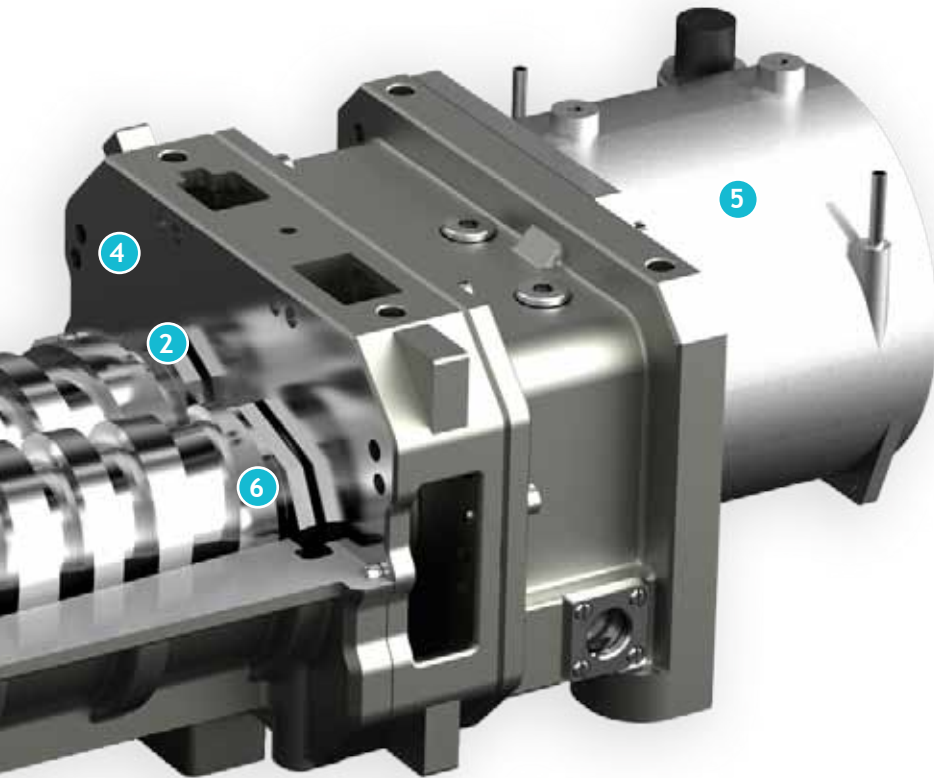

6 Accessories for enhanced reliability

- High-flow inlet purge accessory available to aid powder removal from the pump mechanism
- Solvent flush accessory for in-situ cleaning and removal of sticky substances from the pump mechanism
- Solvent injection accessory for use during vacuum processing
- All accessories controllable via the pump's advanced control system with optional hand-held Pump Display Terminal (PDT)

7 Roots booster mechanism

- High efficiency vacuum booster design
- Optimised for maximum performance with automatic thermal management

GXS Booster

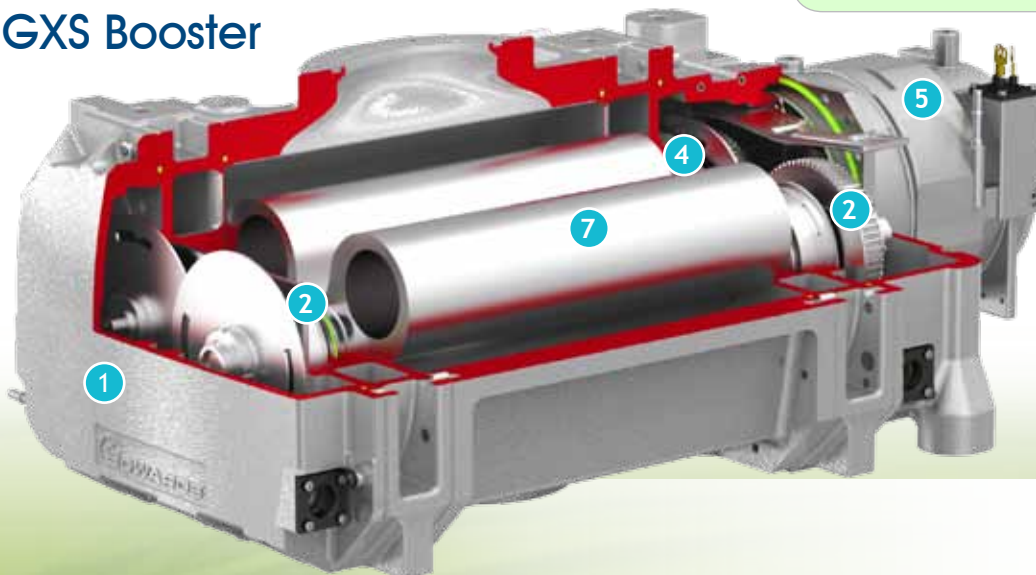

Technical data - GXS160 and GXS250

		Unit
Peak Pumping Speed		m ³ /hr (cfm)
Ultimate Pressure		mbar (Torr)
Full Load Power	@ ultimate pressure	kW (hp)
	@ peak pumping load	kW (hp)
Electrical	Supply options	High volt
		Low volt
	Connection	High volt
		Low volt
Vacuum Couplings	Inlet	
	Exhaust	
Cooling Water	Supply pressure (max)	bar (psig)
	DP across pump (min)	bar (psig)
	Flow @ min DP	l/min (gal/min)
	Temperature	°C (°F)
	Connection	
Purge Gas options*	Pressure	bar (psig)
	Light Duty	sl/min
	Medium Duty	sl/min
	Connection	
High Flow Purge/ Solvent Flush	Supply pressure	bar (psig)
	Control valve connection	
	Filter connection	
	Solvent connection	
Mass		Kg (lbs)
Noise		dB(A)
Operating Temperature		°C (°F)
Exhaust Back Pressure (MAX)		mbar (psia)
System IP rating	Standard	
	Option	
Lubrication	Type	
	Volume	l (gal)
Monitoring & Control	Standard	Control
		Monitoring
	Option	Control
		Control & Monitoring
		Monitoring

GXS160	GXS160/1750	GXS250	GXS250/2600
160 (95)	1200 (706)	250 (148)	1900 (1118)
<1x10 ⁻² (<7.5x10 ⁻³)	<1x10 ⁻³ (<7.5x10 ⁻⁴)	<1x10 ⁻² (<7.5x10 ⁻³)	<1x10 ⁻³ (<7.5x10 ⁻⁴)
3.8 (5.1)	5.1 (6.8)	4.0 (5.4)	5.3 (7.1)
5.0 (6.7)	7.4 (9.9)	9.0 (12.1)	9.7 (13.0)
380-460V 3Ø 50/60Hz		380-460V 3Ø 50/60Hz	
200-230V 3Ø 50/60Hz		200-230V 3Ø 50/60Hz	
Harting Han K 4/4-F		Harting Han K 4/4-F	
ISO63	ISO100	ISO63	ISO160
NW40		NW40	
6.9 (100)		6.0 (100)	
1.0 (14.7)		1.0 (14.7)	
4.0 (1.1)	7.0 (1.9)	4.0 (1.1)	7.0 (1.9)
5-40 (41-104)		5-40 (41-104)	
3/8" BSP Male (G 3/8")		3/8" BSP Male (G 3/8")	
2.5-6.9 (36-100)		2.5-6.9 (36-100)	
12		12	
18-52		18-52	
Swagelok® Ø ¼" tube with olive		Swagelok® Ø ¼" tube with olive	
2.5-6.9 (36-100)		2.5-6.9 (36-100)	
Swagelok® Ø 3/8" tube with olive		Swagelok® Ø 3/8" tube with olive	
½" NPT Male		½" NPT Male	
3/8" BSP Male (G 3/8")		3/8" BSP Male (G 3/8")	
305 (672)	475 (1047)	305 (672)	515 (1035)
<64		<64	
5-40 (41-104)		5-40 (41-104)	
1400 (20)		1400 (20)	
31		31	
54		54	
PFPE Drynert® 25/6		PFPE Drynert® 25/6	
0.7 (0.2)	1.4 (0.4)	0.7 (0.2)	1.4 (0.4)
Front panel "Dashboard" Serial - RS232		Front panel "Dashboard" Serial - RS232	
Ethernet Webserver		Ethernet Webserver	
Parallel - MCM MicroTIM		Parallel - MCM MicroTIM	
Profibus DP Pump Display Terminal (PDT)		Profibus DP Pump Display Terminal (PDT)	
FabWorks®		FabWorks®	

* Purge Gas information

Light duty: shaft seal purge only

Medium duty: Shaft seal purge, inlet purge, variable gas ballast & exhaust purge (with exhaust pressure sensor)

Medium duty plus: As Medium duty, plus High Flow Purge/Solvent Flush

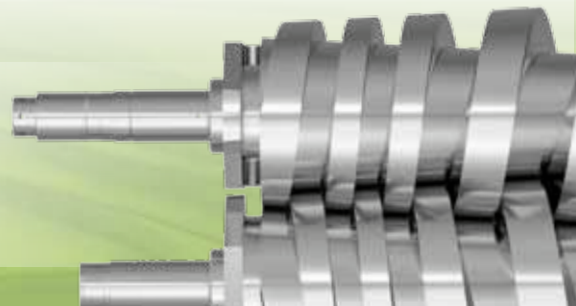



Technical data - GXS450 and GXS750

GXS450	GXS450/2600	GXS450/4200	GXS750	GXS750/2600	GXS750/4200
450 (265)	2200 (1295)	3026 (1781)	740 (436)	2300 (1354)	3450 (2031)
$<1 \times 10^{-2}$ ($<7.5 \times 10^{-3}$)	$<1 \times 10^{-3}$ ($<7.5 \times 10^{-4}$)		$<1 \times 10^{-2}$ ($<7.5 \times 10^{-3}$)	$<1 \times 10^{-3}$ ($<7.5 \times 10^{-4}$)	
6.3 (8.4)	7.3 (9.8)	7.3 (9.8)	8.8 (11.8)	10.8 (14.5)	10.3 (13.8)
16.0 (21.4)	17.0 (22.8)	20.0 (34.9)	26.2 (35.1)	27.3 (36.4)	28.3 (37.9)
380-460V 3Ø 50/60Hz			380-460V 3Ø 50/60Hz		
200-230V 3Ø 50/60Hz			200-230V 3Ø 50/60Hz		
Harting Han K 4/4-F	Harting Han 100A-F		Harting Han 100A-F		
			Harting Han 200A-F		
ISO100	ISO160		ISO100	ISO160	
NW50			NW50		
6.9 (100)			6.9 (100)		
1.5 (22)			1.5 (22)		
12 (3.2)			12 (3.2)		
5-40 (41-104)			5-40 (41-104)		
3/8" BSP Male (G 3/8")			3/8" BSP Male (G 3/8")		
2.5-6.9 (36-100)			2.5-6.9 (36-100)		
12			12		
18-146			18-146		
Swagelok® Ø 1/4" tube with olive			Swagelok® Ø 1/4" tube with olive		
2.5-6.9 (36-100)			2.5-6.9 (36-100)		
Swagelok® Ø 3/8" tube with olive			Swagelok® Ø 3/8" tube with olive		
1/2" NPT Female			1/2" NPT Female		
3/8" BSP Male (G 3/8")			3/8" BSP Male (G 3/8")		
640 (1411)	860 (1996)	868 (1914)	640 (1411)	908 (2002)	953 (2101)
<64			<70		
5-40 (41-104)			5-40 (41-104)		
1400 (20)			1400 (20)		
31			31		
54			54		
PFPE Drynert® 25/6			PFPE Drynert® 25/6		
1.8 (0.5)	2.5 (0.7)	3.6 (1.0)	2.4 (0.6)	3.1 (0.8)	4.2 (1.1)
Front panel "Dashboard" Serial - RS232			Front panel "Dashboard" Serial - RS232		
Ethernet Webserver			Ethernet Webserver		
Parallel - MCM MicroTIM			Parallel - MCM MicroTIM		
Profibus DP Pump Display Terminal (PDT)			Profibus DP Pump Display Terminal (PDT)		
FabWorks®			FabWorks®		

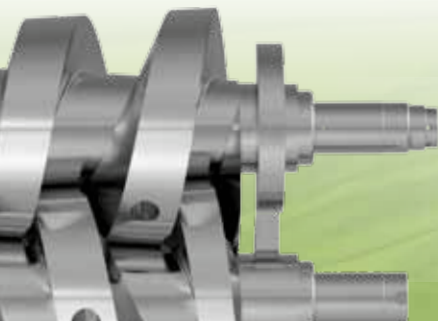

Dimensions

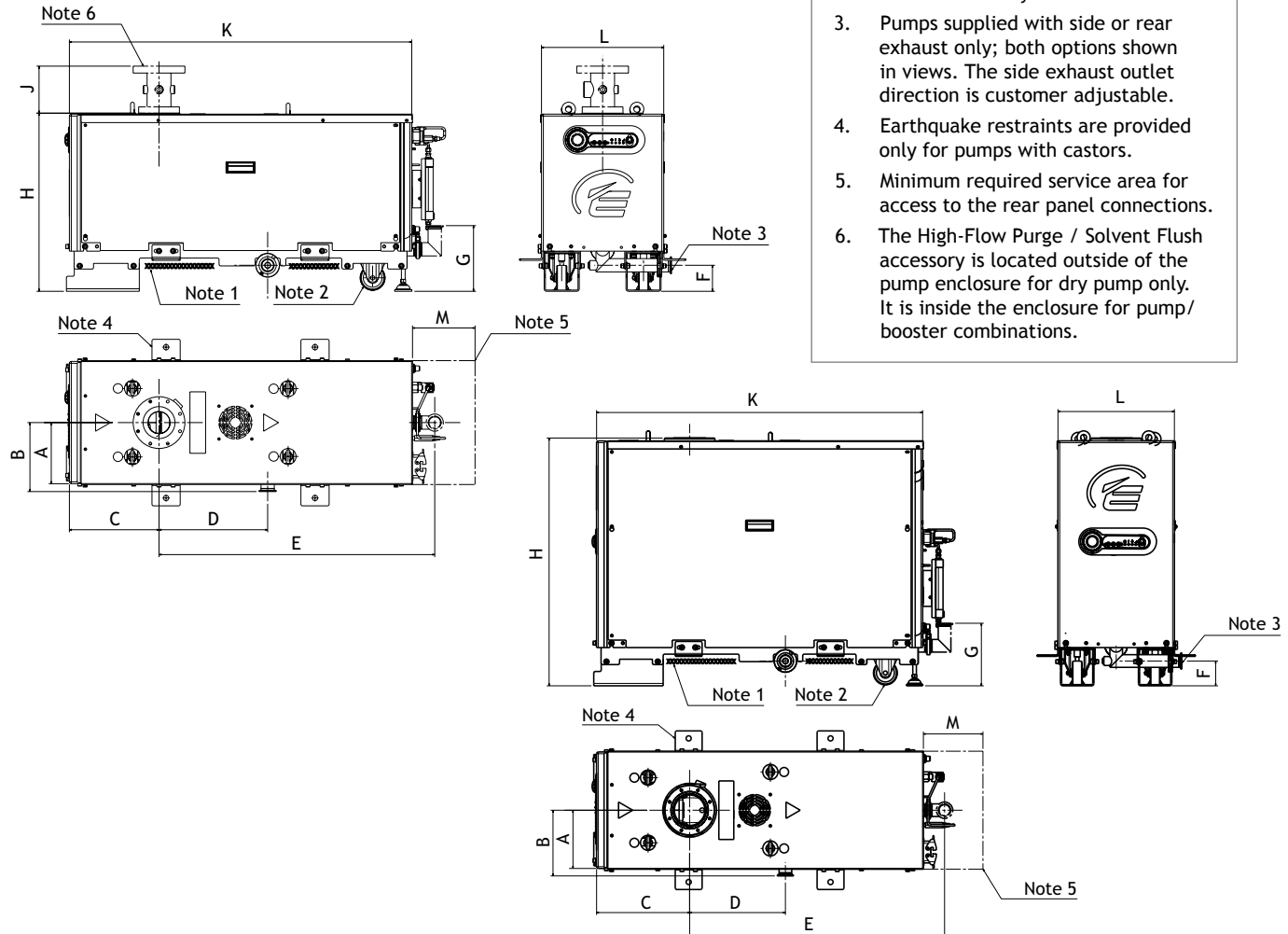

- Notes:**
- xxxxxx indicate forklift/pallet truck access points.
 - Pumps are available either with skids (side-exit exhaust) or castors (rear-exit exhaust). Both options are shown for clarity.
 - Pumps supplied with side or rear exhaust only; both options shown in views. The side exhaust outlet direction is customer adjustable.
 - Earthquake restraints are provided only for pumps with castors.
 - Minimum required service area for access to the rear panel connections.
 - The High-Flow Purge / Solvent Flush accessory is located outside of the pump enclosure for dry pump only. It is inside the enclosure for pump/booster combinations.

	A	B	C	D	E	F	G	H	J	K	L	M		
GXS160	195 (7.68)	220 (8.66)	285.9 (11.26)	346.5 (13.64)	879.5 (34.63)	83 (3.27)	209.4 (8.24)	568 (22.36)	150 (5.9)	1092 (42.99)	390 (15.35)	250 (9.84)		
GXS250			311.6 (12.27)		853.8 (33.61)			829.5 (32.66)	-					
GXS160/1750			394 (15.51)		300 (11.81)			871.6 (34.31)	717 (28.23)				150 (5.9)	1186 (46.69)
GXS250/2600			576.4 (22.69)		413 (16.23)			1133.6 (44.63)	1622 (63.86)					
GXS450	258.5 (10.18)	283.5 (11.16)	361.8 (14.24)	332.3 (13.08)	903.8 (33.58)		261.4 (10.29)	1030.5 (40.57)	-	-	1186 (46.69)	517 (20.35)	250 (9.84)	
GXS450/2600			657.2 (25.87)		1052.8 (41.45)									1622 (63.86)
GXS450/4200														
GXS750														
GXS750/2600														
GXS750/4200														

Key pump dimensions: mm (ins)



Performance curves

Pumping Speed Curves for GXS160 & GXS250

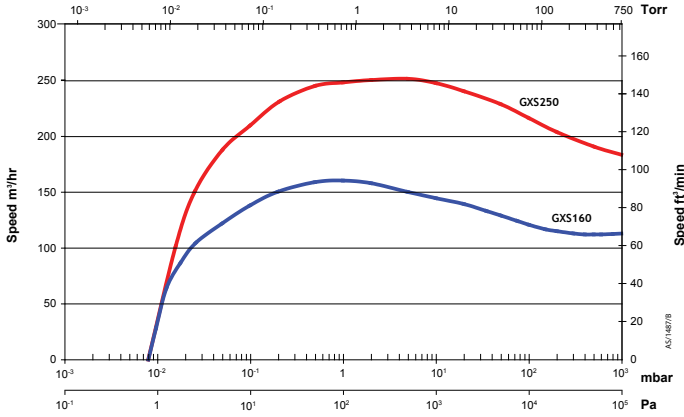

Pumping Speed Curves for GXS160/1750 & GXS250/2600

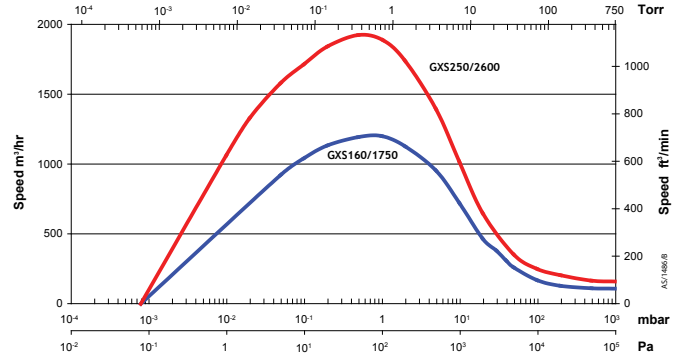

Pumping Speed Curves for GXS450

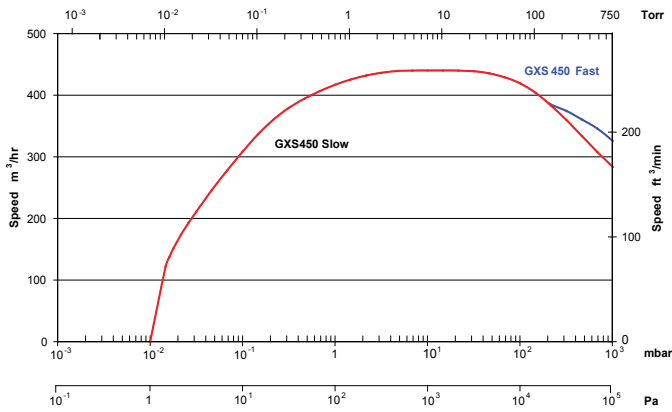

Pumping Speed Curves for GXS450/2600 & GXS450/4200

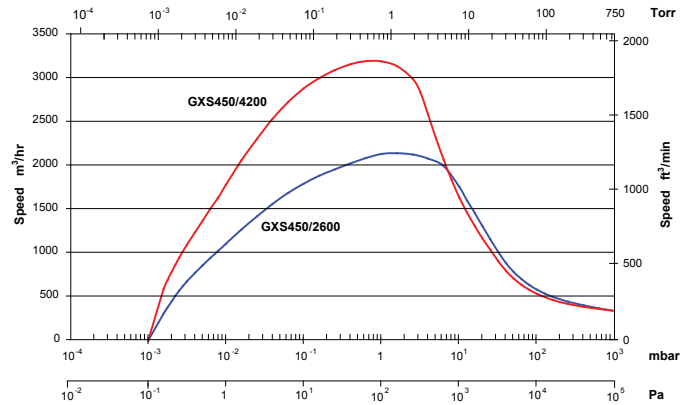

Pumping Speed Curves for GXS750

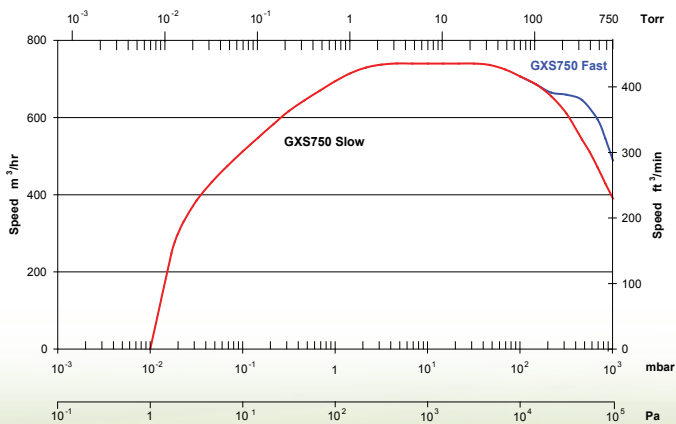

Pumping Speed Curves for GXS750/2600 & GXS750/4200

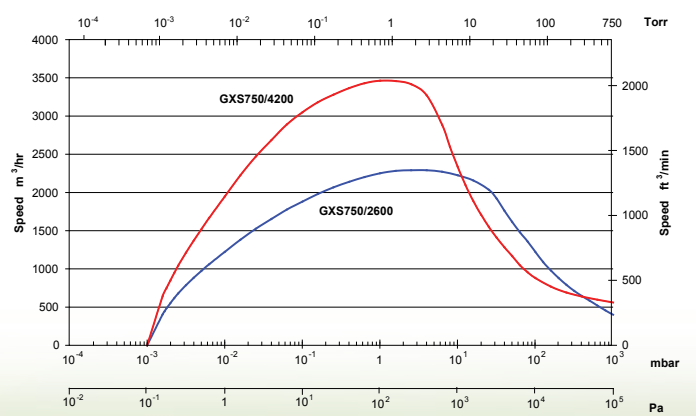



GXS Ordering Information

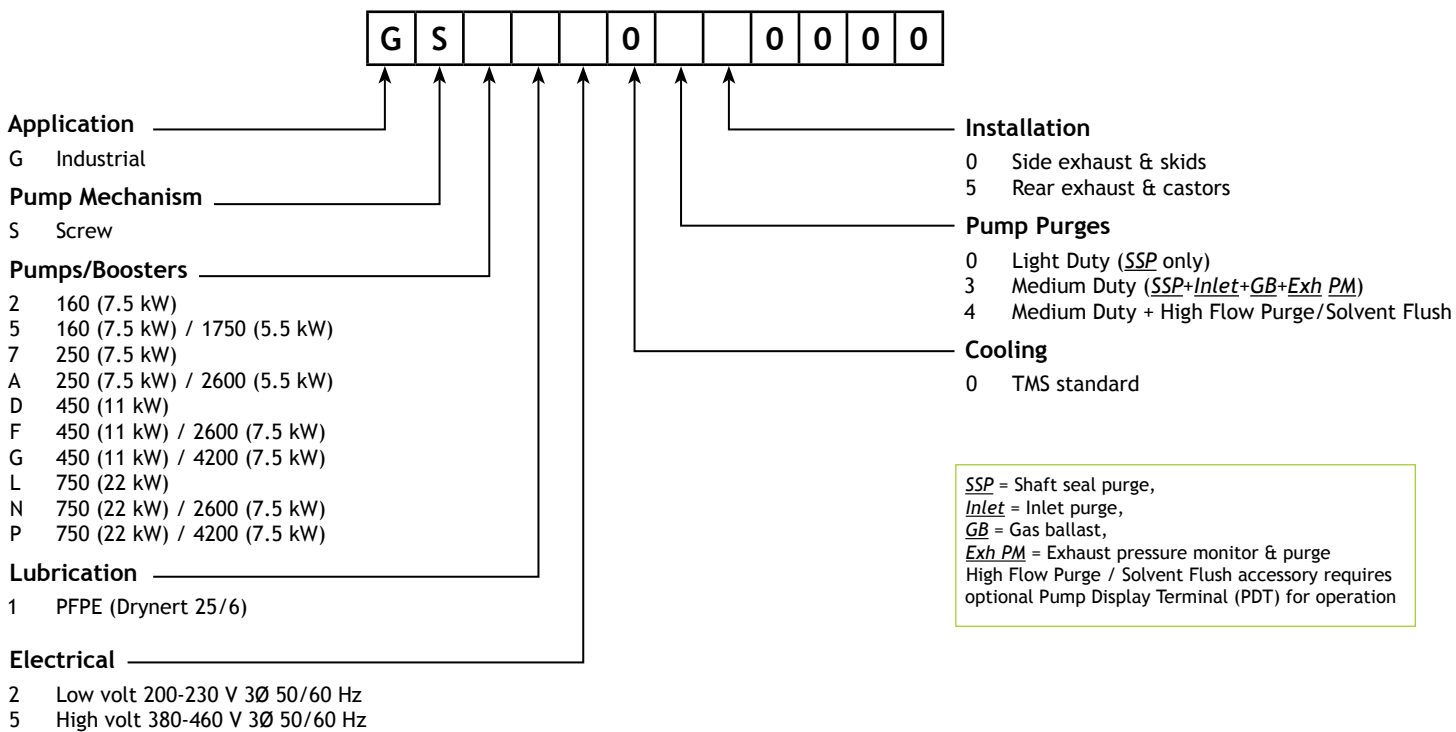

SSP = Shaft seal purge,
Inlet = Inlet purge,
GB = Gas ballast,
Exh PM = Exhaust pressure monitor & purge
 High Flow Purge / Solvent Flush accessory requires optional Pump Display Terminal (PDT) for operation

Recommended Accessory:

Pump Display Terminal (PDT)* D37280700

*Access to full functionality for Medium Duty & Medium Duty+ pumps requires a PDT

Optional Accessories:

GXS Auxilliary gauge cable (0-10V)	D37241017
GXS Pressure input cable (4-20mA)	D37241019
MCM MicroTIM	D37360320
Connector kit for MCM MicroTIM**	D37422802
Profibus® Module	D39753000
Cooling water flow monitoring switch	A50783000
Purge gas flow switch options	
160 LD/MD/MD+, 250 LD/MD/MD+, 450 LD, 750 LD	A50784000
450 MD/MD+, 750 MD/MD+	A50785000

** Required to build interface cable



Global Contacts

EUROPE

UK Crawley +44 1293 528844
 UK Local Rate (UK only) 08459 212223
 Belgium Brussels +32 2 300 0730
 France Paris +33 1 4121 1256
 Germany Munich 0800 000 1456
 Italy Milan +39 02 48 4471

USA

Toll free (USA only) +1 800 848 9800

BRAZIL

Sao Paulo +55 11 3952 5000

ISRAEL

Qiryat-Gat +972 8 681 0633

ASIA PACIFIC

China, Shanghai +86 21 5866 9618
 India, Pune +91 20 4075 2222
 Japan, Yachiyo +81 47 458 8831
 Korea, Bundang +82 31 716 7070
 Singapore +65 6546 8408
 Taiwan R.O.C. Jhunan Town +886 3758 1000



WWW.EDWARDSVACUUM.COM

info@edwardsvacuum.com

Rev 01/2011
 Publication Number: M58800895, Issue B
 © Edwards Limited 2011. All rights reserved.
 Edwards and the Edwards logo are trade marks of Edwards Limited.